



General Information



- Danfoss LX205T WIFI App (for iOS & Android) allows remote access, and a convenient way to adjust/monitor the system from any location
- 3.5" color screen with easy interactive touch control
- New Easy Scheduling method and even easier on the fly changes
- Track power consumption and save it to a PC with a few simple steps
- Thermostat settings can be exported to web page for support
- Universal compatibility with existing floor heating sensors
- Suitable for tile, stone, laminate, concrete and engineered wood floor applications
- 5 year battery backup of clock and calendar
- Sleek design - Patent pending

The LX205T WIFI Touch thermostat is designed for electric floor heating applications. It features a new sleek design, intuitive control, & easy to install process. Benefits Include:

Technical Data

WLAN (WIFI) Connectivity:	802.11 b.g.n WLAN module. Port 80 access.
Supply:	120-240 VAC, 50/60 Hz
Max. Load:	15A maximum (resistive load)
Power:	1800W at 120 VAC / 3120W at 208 VAC / 3600W at 240 VAC
GFCI:	Class A (5 mA trip level)
Temperature Range:	41°F to 104°F (5°C to 40°C)
Floor Limit Range:	41°F to 104°F (5°C to 40°C)
Ambient Temp. Range:	32°F to 104°F (0°C to 40°C)
On/Off Differential:	0.7°F (0.4°C)
Regulation Principle:	PWM / PI
Housing:	NEMA 1 (IP20)
Floor Sensor Type:	NTC (10 KΩ) 15 ft. (4.5 m)
Dimensions (HxWxD):	5.1" x 3.2" x 0.8" (130mm x 82mm x 20mm)
Wall box (HxWxD):	3"x2"x2" (76mm x 51mm x 51mm)
Display:	3.5" (89mm), 65k color
Touch:	resistive
Programmable events:	1-6 event per day
Features:	Child lock
Control Modes:	Ambient temp. w/ floor protection, Floor temp. w/ floor protection, Ambient temp. w/o floor protection (regulator mode without sensor)

Dimensions in (mm)

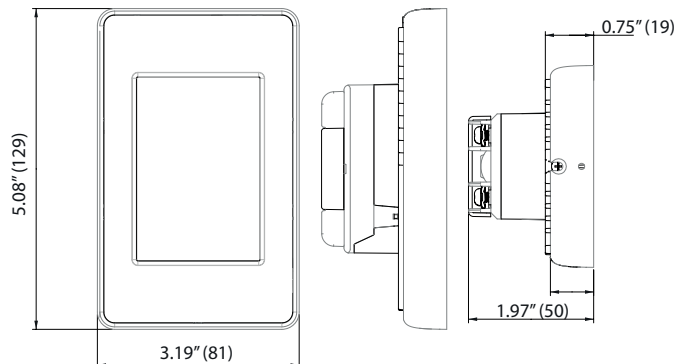



Typical Application

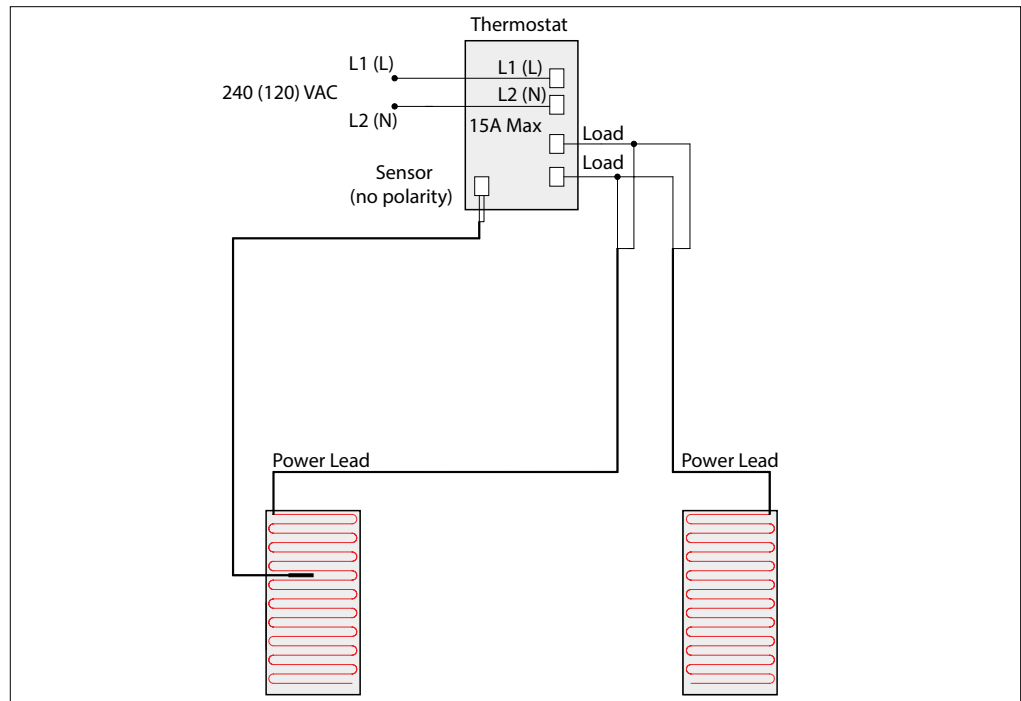

Ordering Information

Part No.	Description
088L5140	LX205T WIFI Programmable Touch Thermostat

Applications

Products in this data sheet are for use with these Danfoss mats and cables:

Danfoss Electric Heating Products
LX Electric Floor Heating Mats and Cables
TX-FH Floor Heating Cables
TX-SH Storage Heating Cables

Accessories

Part No.	Description
088L5135	Power Module with GFCI (15 Max. Amps)
088L3450	Single Contactor, 3P, 600V Max (120V Max Amps, 120V Coil Voltage)
088L3451	Single Contactor, 3P, 600V Max (120V Max Amps, 208V-240V Coil Voltage)
ETF-110/99C	Replacement Thin Floor Sensor (10K Ω)

Warranty

Danfoss offers a two year limited warranty covering defects in workmanship and materials.

Technical Services

For technical questions, please contact Danfoss Heating Division North America at **1-888-DANFOSS**. More information on Danfoss Electric Heating products is available at **www.LX.Danfoss.com**.

Danfoss can accept no responsibility for possible errors in catalogs, brochures, other printed materials, and website information. Danfoss reserves the right to alter its products without notice. This also applies to products already on order provided that such alteration can be made without subsequent changes being necessary in specifications already agreed upon. All trademarks in this material are property of the respective companies. Danfoss and Danfoss logotype are trademarks of Danfoss A/S. All rights reserved.



Danfoss

Toll Free: 1-888-DANFOSS (326-3677)
 Fax: 416-352-5981
 www.LX.Danfoss.com

Danfoss LX
 BRINGING WARMTH TO LIFE